

Profibus DP Interface User Guide



Caution

This option module is specifically designed to be used with the Synergy range of soft-start products and is intended for professional incorporation into complete equipment or systems. If installed incorrectly it may present a safety hazard. Before commencing installation and commissioning, the user should ensure they are fully familiar with the Synergy unit, and in particular have read the important safety information and warnings contained in the Synergy User Guide.

Overview

The Profibus DP Interface is intended to be installed in the Synergy option slot, and allows the Synergy to be connected to an Profibus DP network. The interface offers the following functionality:-

Installation

- Ensure all power is removed from the Synergy unit prior to installing the option module
- Remove the blanking plate from the option module slot
- Carefully slide the option module into the slot, ensuring that the location tabs are correctly aligned. **DO NOT USE EXCESSIVE FORCE**
- Tighten the two screws on the option module to secure

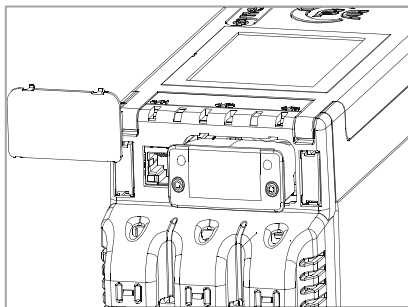

Synergy configuration

Synergy will automatically configure when the option module is installed. Correct installation can be confirmed from the touch screen interface:

Device >> Networks >> Profibus

Front panel

Item	
1	Operation mode
2	Status
3	Profibus network connector

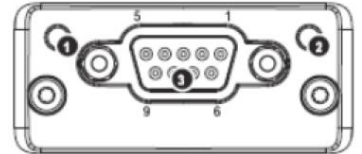

Operation mode

State	Indication
Off	No power or not inserted
Green	Online data exchange
Green, flashing	Network OK, no data exchange
Single Red flash	Parameter error
Double Red flash	Network error

Status

State	Indication
Off	No power
Green	Initialised
Green, flashing	Initialised, Self testing
Red	Error

Profibus DP Connector Pinout

Pin	Function
1	N/C
2	N/C
3	B line Positive Rx/D/TxD, RS485
4	RTS
5	Bus Ground (GND)
6	+5V Bus output termination power
7	N/C
8	A Line negative Rx/D/TxD, RS485
9	N/C

GSD File

A GSD file for the interface is available from www.fairford.com

PLC Configuration

Configuration of the PLC varies between different systems. When configuring the Profibus network in the PLC, it is important to ensure that the output data sent from the PLC to the drive is in a lower slot number than the input data from the drive back to the PLC. Refer to information on the specific PLC system in use for further guidance

Synergy Profibus DP control

The current Profibus interface for this device is specified in the `sgy1000.gsd` file. This contains the configuration required to run the synchronous standard telegram 1 allowing start/stop and fault monitoring of the Synergy unit.

The standard telegram consists of two 16 bit set-point words. The first being the drive control word.

This has the following functionality.

Output Word 1 (STW1)							
Bit 7	Bit 6	Bit 5	Bit 4	Bit 3	Bit 2	Bit 1	Bit 0
Fault Reset	-	Unfreeze Ramp	Ramp On	Enable Operation	Coast Stop	-	Start
Bit 15	Bit 14	Bit 13	Bit 12	Bit 11	Bit 10	Bit 9	Bit 8
-	-	-	-	-	Network Connect	-	-

The second Profibus Standard telegram 1 set-point word (NSOLL_A) is not implemented in this version so will not respond to set values.

The response telegram also consists of two words, this time values generated by the Synergy unit in response to the set-points. The first word holds status information and has the following meaning.

Input Word 1 (ZSW1)							
Bit 7	Bit 6	Bit 5	Bit 4	Bit 3	Bit 2	Bit 1	Bit 0
-	Switch on Inhibited	Quick Stop Disabled	Same as Bit 0	Fault (Tripped)	Operation Enabled	Switched On	Ready Switch On
Bit 15	Bit 14	Bit 13	Bit 12	Bit 11	Bit 10	Bit 9	Bit 8
Bit 1	-	-	-	-	-	Network Connected	-

As with the Outputs the second Profibus Standard telegram 1 value word (NIST_A) is not implemented in this version so should be ignored.